

NSF 61 RESIN
UV15 RATED
1.9 SPECIFIC GRAVITY STANDARD
ATMOSPHERIC PREASURE ONLY
THREADED OR FLANGED FITTINGS AVAILABLE
16" VENTED LID STANDARD
AVAILABLE IN COLORS
AVAILABLE IN POLYPROPYLENE AND PVDF

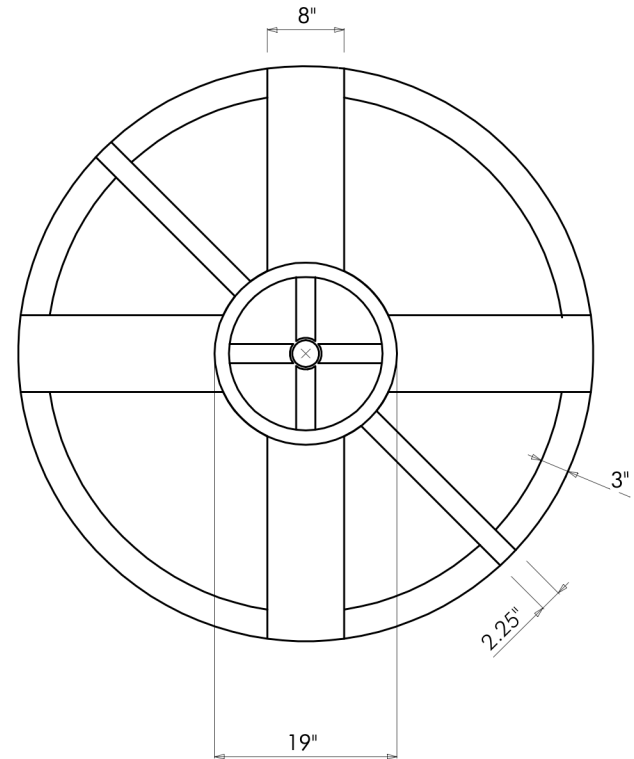

				DRAWN BY / DATE DHALL / 11-13-17		MATERIAL / SHOT WEIGHT			
						HDPE 280 LBS.			
				APPROVED BY / DATE		NOTES:		CLIENT/DESCRIPTION 1,000 GALLON VERTICAL TANK	
REV DESCRIPTION DATE APPRD								SCALE N.S.	
All dimensions are in decimal inches Tolerances unless otherwise specified +/- .5% at 68 degrees F.				THIRD ANGLE PROJECTION ANSI 14.5M 					