

| REVISIONS | | | | |
|-----------|-----|-------------|---------|----------|
| ZONE | REV | DESCRIPTION | DATE | APPROVED |
| | A | REDRAWN | 09SEP97 | |

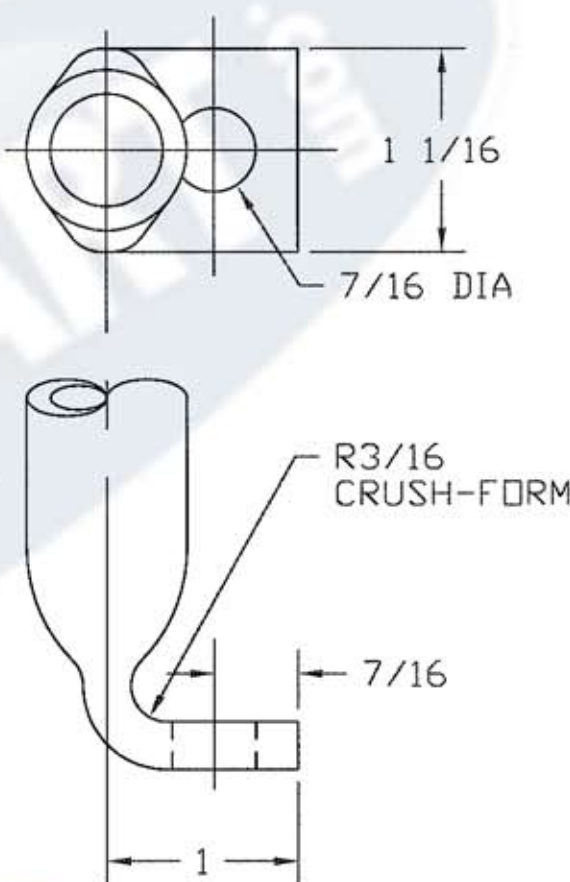
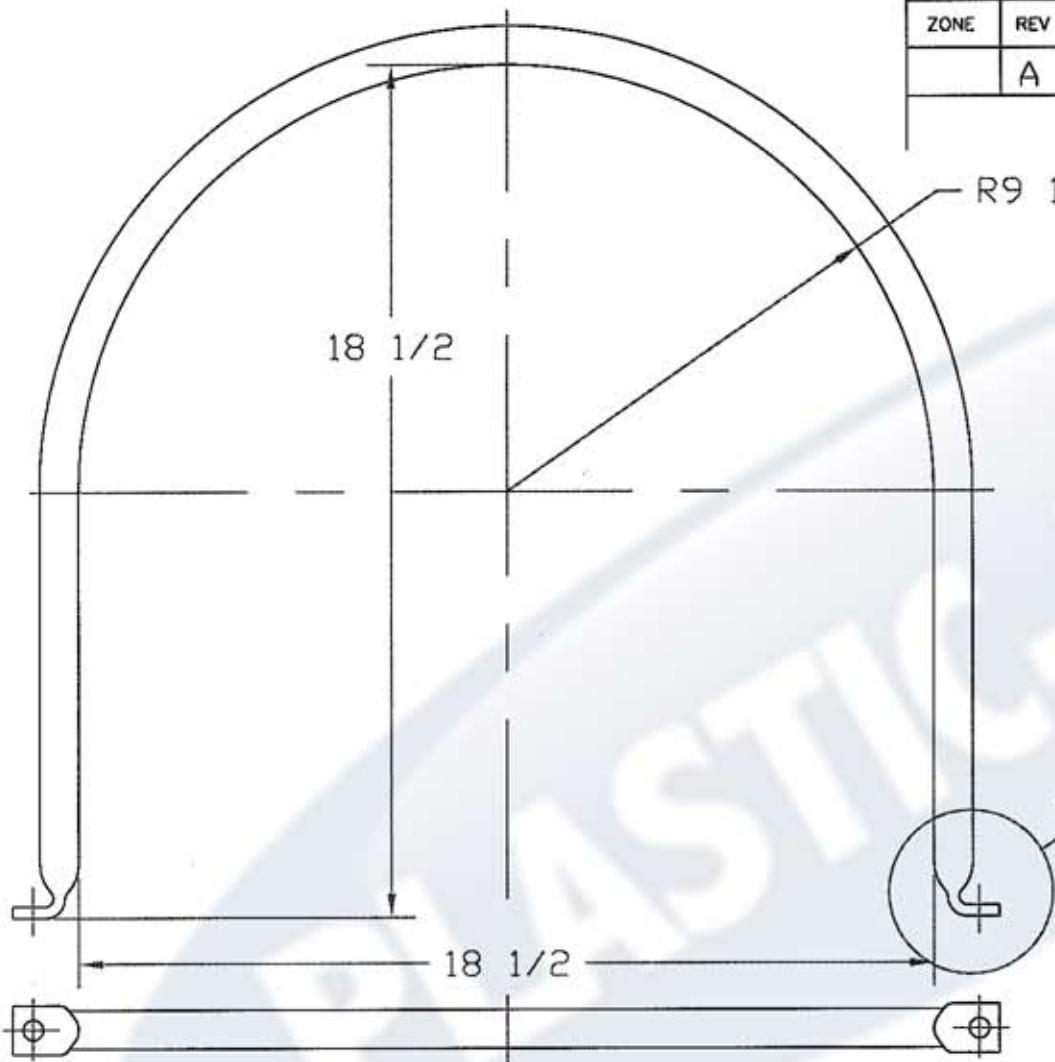

MAT'L: 1/2" GALVANIZED EMT CONDUIT

PLASTIC-MART 866-310-2556

BAND, 35 GALLON
HORIZONTAL TANK

| | | | | | |
|-----|---------|-----------|----------|---------|----------|
| JTP | 09SEP97 | SIZE A | FSCM NO. | DWG NO. | REV A |
| | | SCALE 1/4 | | | SHEET |